

U-Type[®] Secondary Belt Cleaner

Installation, Operation and Maintenance Manual

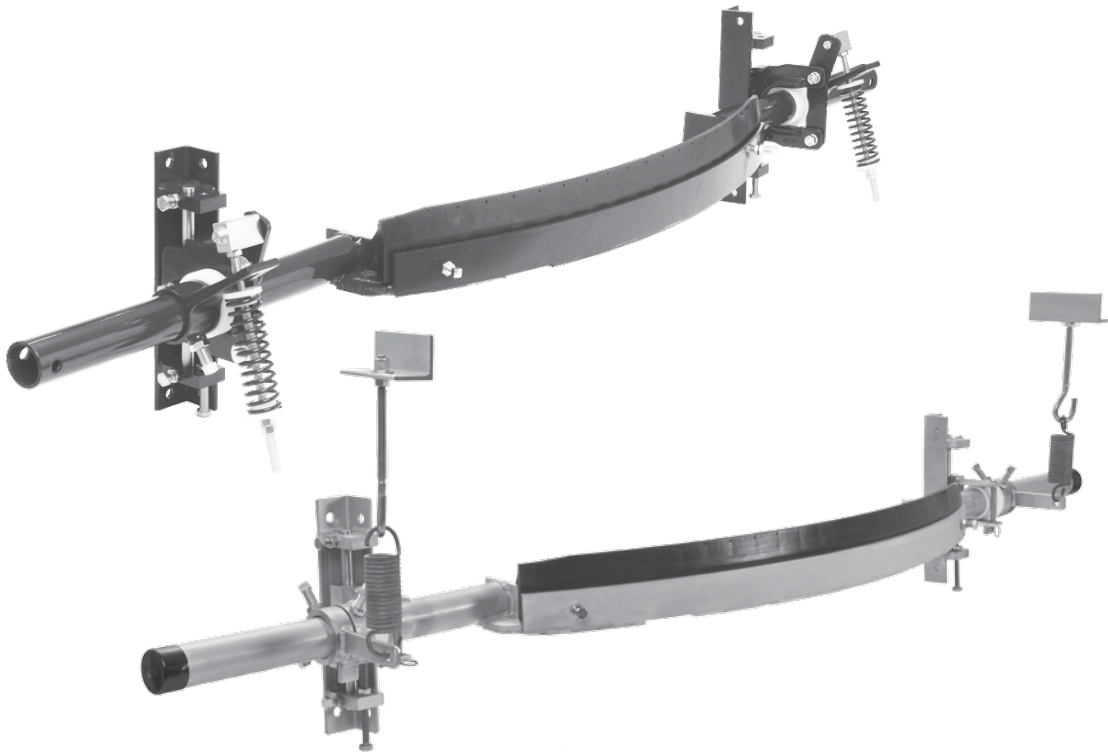

U-Type Secondary Cleaner

Serial Number:	_____
Purchase Date:	_____
Purchased From:	_____
Installation Date:	_____

Serial number information can be found on the Serial Number Label included in the Information Packet shipped in the cleaner carton.

This information will be helpful for any future inquiries or questions about belt cleaner replacement parts, specifications or troubleshooting.

Table of Contents

Section 1 - Important Information	2
1.1 General Introduction.....	2
1.2 User Benefits	2
1.3 Service Option	2
Section 2 - Safety Considerations and Precautions	3
2.1 Stationary Conveyors.....	3
2.2 Operating Conveyors.....	3
Section 3 - Pre-Installation Checks and Options.....	4
3.1 Checklist.....	4
3.2 Optional Installation Accessories.....	4
3.3 Correct Blade Installation and Tensioning	5
Section 4 - Installation Instructions.....	6
Section 5 - Pre-Operation Checklist and Testing.....	12
5.1 Pre-Op Checklist.....	12
5.2 Test Run the Conveyor	12
Section 6 - Maintenance.....	13
6.1 New Installation Inspection.....	13
6.2 Routine Visual Inspection.....	13
6.3 Routine Physical Inspection	13
6.4 Blade Replacement Instructions.....	14
6.5 Maintenance Log.....	16
6.6 Cleaner Maintenance Checklist.....	17
Section 7 - Troubleshooting	18
Section 8 - Specs and CAD Drawings.....	19
8.1 Specs and Guidelines	19
8.2 CAD Drawing - Cleaners with UST Tensioners	20
8.3 CAD Drawing - Cleaners with J-Bolt Tensioners	21
Section 9 - Replacement Parts	22
9.1 Replacement Parts List- U-Type with UST Tensioners.....	22
9.2 Replacement Parts List- Stainless Steel U-Type with J-Bolt Tensioners	23
9.3 Replacement Blades	24
Section 10 - Other Flexco Conveyor Products	25

Section 1 - Important Information

1.1 General Introduction

We at Flexco are very pleased that you have selected a U-Type® Secondary Cleaner for your conveyor system.

This manual will help you to understand the operation of this product and assist you in making it work up to its maximum efficiency over its lifetime of service.

It is essential for safe and efficient operation that the information and guidelines presented be properly understood and implemented. This manual will provide safety precautions, installation instructions, maintenance procedures and troubleshooting tips.

If, however, you have any questions or problems that are not covered, please contact your field representative or our Customer Service Department:

Web site: Flexco.com

Customer Service: USA: 1-800-541-8028

Australia: 61-2-9680-3322 • China: 86-21-33528388

England: 44-1274-600-942 • Germany: 49-7428-9406-0

Mexico: 52-55-5674-5326 • South Africa: 27-11-608-4180

Please read this manual thoroughly and pass it on to any others who will be directly responsible for installation, operation and maintenance of this cleaner. While we have tried to make the installation and service tasks as easy and simple as possible, **it does however require correct installation and regular inspections and adjustments to maintain top working condition.**

1.2 User Benefits

Correct installation and regular maintenance will provide the following benefits for your operation:

- Reduced conveyor downtime
- Reduced man-hour labor
- Lower maintenance budget costs
- Increased service life for the belt cleaner and other conveyor components

1.3 Service Option

The U-Type Secondary Cleaner is designed to be easily installed and serviced by your on-site personnel. However, if you would prefer complete turn-key factory service, please contact your local Flexco Field Representative.

Section 2 - Safety Considerations and Precautions

Before installing and operating the U-Type Secondary Cleaner, it is important to review and understand the following safety information.

There are set-up, maintenance and operational activities involving both **stationary** and **operating** conveyors. Each case has a safety protocol.

2.1 Stationary Conveyors

The following activities are performed on stationary conveyors:

- Installation
- Blade replacement
- Repairs
- Tension adjustments
- Cleaning

DANGER

It is imperative that OSHA/MSHA Lockout/Tagout (LOTO) regulations, 9 CFR 1910.147, be followed before undertaking the preceding activities. Failure to use LOTO exposes workers to uncontrolled behavior of the belt cleaner caused by movement of the conveyor belt. Severe injury or death can result.

Before working:

- Lockout/Tagout the conveyor power source
- Disengage any takeups
- Clear the conveyor belt or clamp securely in place

WARNING

Use Personal Protective Equipment (PPE):

- Safety eyewear
- Hardhats
- Safety footwear

Close quarters, springs and heavy components create a worksite that compromises a worker's eyes, feet and skull.

PPE must be worn to control the foreseeable hazards associated with conveyor belt cleaners. Serious injuries can be avoided.

2.2 Operating Conveyors

There are two routine tasks that must be performed while the conveyor is running:

- Inspection of the cleaning performance
- Dynamic troubleshooting

DANGER

Every belt cleaner is an in-running nip hazard. Never touch or prod an operating cleaner. Cleaner hazards cause instantaneous amputation and entrapment.

WARNING

Belt cleaners can become projectile hazards. Stay as far from the cleaner as practical and use safety eyewear and headgear. Missiles can inflict serious injury.

WARNING

Never adjust anything on an operating cleaner. Unforseeable belt projections and tears can catch on cleaners and cause violent movements of the cleaner structure. Flailing hardware can cause serious injury or death.

Section 3 - Pre-Installation Checks and Options

3.1 Checklist

- Check that the cleaner size is correct for the beltline width
- Check the belt cleaner carton and make sure all the parts are included
- Review the “Tools Needed” list on the top of the installation instructions
- Check the conveyor site:
 - Will the cleaner be installed on a chute
 - Is the install on an open head pulley requiring mounting structure (see 3.3 - Optional Installation Accessories)

3.2 Optional Installation Accessories

Versatile, adjustable brackets that can be mounted on the conveyor structure so the U-Type cleaner can be quickly and easily bolted into place. Pole extenders are also available for wide, non-standard conveyor structures.

75666

Mounting Bracket Kit

(includes 1 left and 1 right bracket)

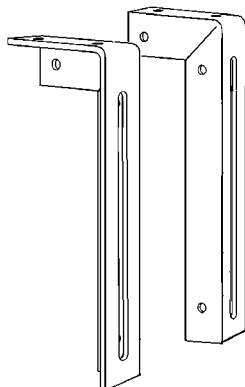

76024

Pole Extender Kit

(includes 2 pole extenders)

- For cleaner sizes 72" (1800mm) and larger
- Provides 30" (750mm) of extended pole length

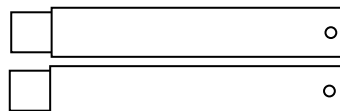

Optional Installation Accessories			
Description	Ordering Number	Item Code	Wt. Lbs.
Mounting Bracket Kit	EZS2MBK	75666	13.0
Pole Extender Kit	MAPEK	76024	21.9

Section 3 - Pre-Installation Checks and Options

3.3 Correct Blade Installation and Tensioning

For optimal cleaning efficiency and long wear life, the U-Type blade must be located and tensioned correctly on the belt. If the cleaner pole is in the wrong location the performance of the new blade may be adversely affected. See “Possible Problems” below. For tensioning, please follow these instructions.

Correct Pole Location:

When the blade contacts the belt (before tensioning) there should be blade-to-belt contact across the entire blade (Fig. 1). If contact is more in the center with a gap on the outer edges, the pole will need to be raised until full contact is achieved (Fig. 2). If contact is more on the outer edges with a gap in the center, the pole will need to be lowered until full contact is achieved (Fig. 3).

Possible Problems:

- Pole location too low - The initial cleaning will be concentrated in the center of the belt, failing to clean the outer edges efficiently.
- Pole location too high - The initial cleaning will be concentrated to the outer edges of the belt, failing to efficiently clean the center of the belt.
- Tension too low - Without the optimal tension, the cleaning efficiency is reduced and chatter or bouncing of the blade can occur.
- Tension too high - Although the cleaning may appear efficient, accelerated blade wear may occur; and in some cases less efficiency on the outer edges of the belt, which could result in increased belt wear.

Correct Tensioning:

Correct tension is determined and set by blade width. Check the information provided with the tensioner being used or consult the installation instructions.

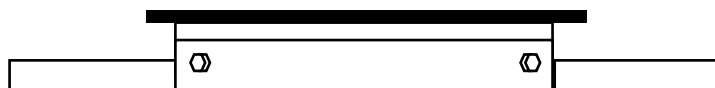

Fig. 1



Fig. 2

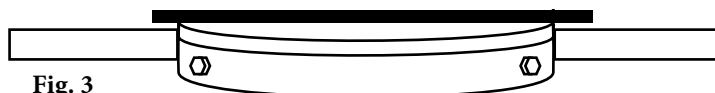
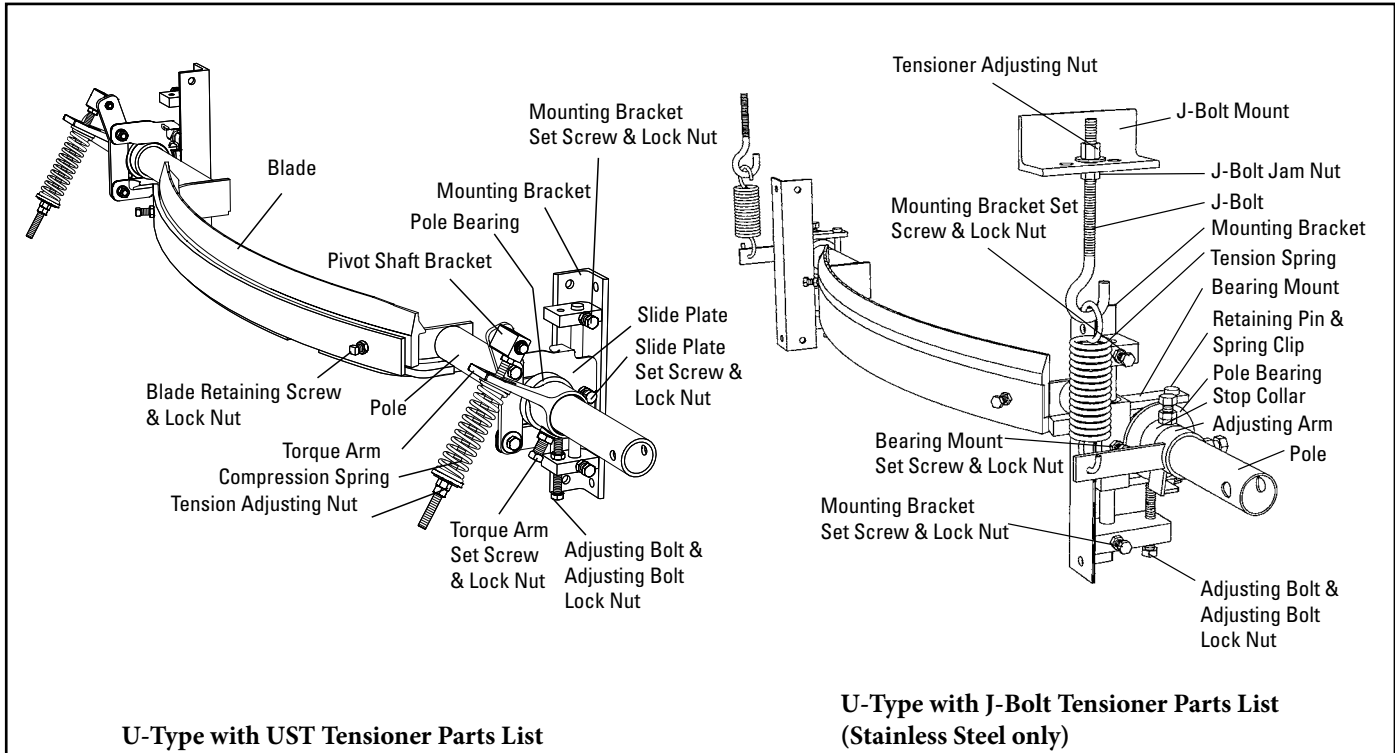

Fig. 3

Section 4 - Installation Instructions

4.1 U-Type Cleaner



Physically lock out and tag the conveyor at the power source before you begin cleaner installation.

Tools Needed:

- Tape measure
- 3/4" (19mm) wrench
- Ratchet with 3/4" (19mm) socket
- Screwdriver
- (2) 6" C-clamps (optional for locating mounting brackets)
- Square (optional for locating belt height)
- Permanent marker
- Cutting torch and/or welder

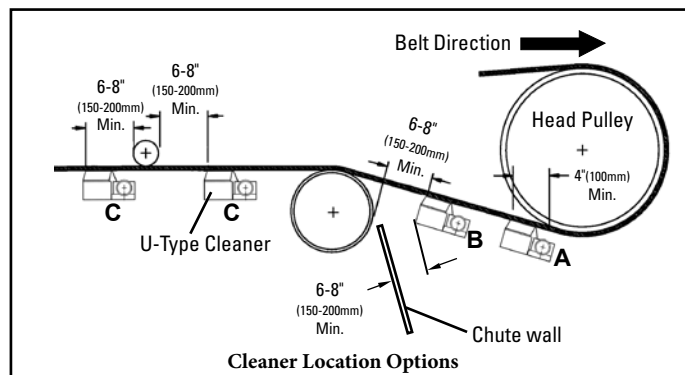

Before You Begin:

- Double-check the blade type needed for your application:
 F-Blade - for mechanically spliced belts.
 C-Blade - for Flexco Solid Plate mechanically spliced and vulcanized belts.
 V-Blade - for vulcanized belts. Can be used with mechanical splices (solid bolt fasteners) that are recessed (skived) into the belt cover (bolts must be ground on plate fasteners).
- For chute mounting it is necessary to cut an access hole. See access hole dimensions on page 7.
- Follow all safety precautions when using a cutting torch.
- If welding, protect all fastener threads from weld spatter.
- For cleaner clearance requirements see chart on page 7.

Section 4 - Installation Instructions (cont.)

Chute Mounting Access Hole Dimensions	
Belt Width	H Dimension
18" - 42" (450-1050mm)	8" (200mm)
48" - 84" (1200-2100mm)	10" (250mm)

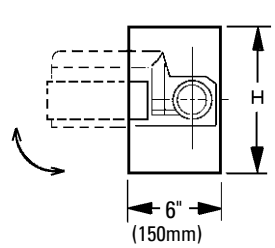

Cleaner Clearance Requirements							
U Cleaner Size		Clearance		U Cleaner Size		Clearance	
in.	mm	in.	mm	in.	mm	in.	mm
18"	450	5 1/2	140	48"	1200	9 1/2	242
24"	600	6 1/2	166	54"	1350	9 1/2	242
30"	750	7 1/2	191	60"	1500	9 1/2	242
36"	900	7 1/2	171	72"	1800	10 1/4	261
42"	1050	8 1/2	217	84"	2100	10 1/4	261

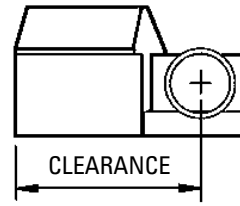

1. Choose conveyor location where cleaner will be installed.

The U-Type may be positioned at any spot from where belt leaves head pulley on down the conveyor line (see positions A to B). If a chute area is too small due to a snub pulley, it may be necessary to mount cleaner behind chute (see position C). In chute applications a minimum of 6"-8" (150-200mm) is required between cleaner and chute wall to prevent clogging of material.

NOTE: For U-Type cleaners using UST Tensioners, proceed to steps 2U - 6U.

For U-Types using J-Bolt Tensioners, skip ahead to Steps 2J - 8J.

UST Tensioner Instructions

2U. Install mounting brackets.

- Using a square, lightly raise return side belt (take out cupping or sagging on edges) to find belt's true parallel path to the structure; and mark reference point #1 on structure. Measure down 3" (75mm) from reference point #1 and mark reference point #2 (Fig. 2Ua).
- Position mounting brackets so centerline marks on brackets are in line with reference points #2 on the structure (Fig. 2Ub).
- Clamp or weld into position.

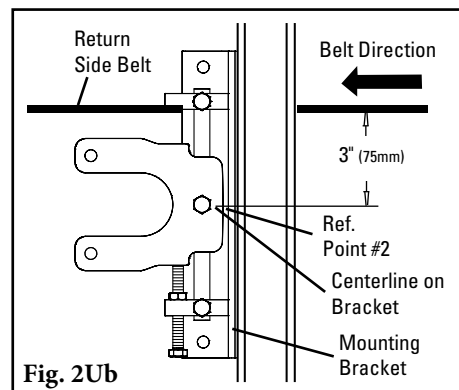
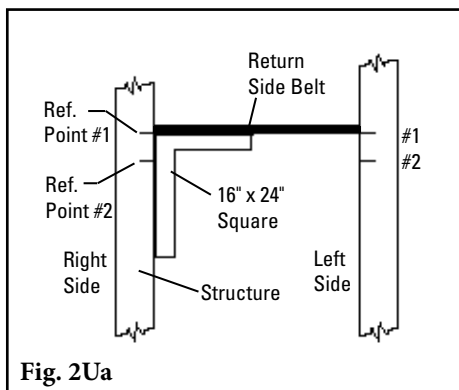

Section 4 - Installation Instructions (cont.)

3U. Install the cleaner pole into the slider plates.

- Attach pivot shaft bracket on one slider plate and insert one pole bearing with flange facing away from the belt (Fig. 3Ua).
- Slide pole through pole bearing and torque arm, then position it into the other slider plate.
- Slide second pole bearing and torque arm onto pole and attach pivot shaft bracket to remaining slider plate (Fig. 3Ub).
- Blade and torque arm must face in the direction of belt travel (Fig. 3Uc). If clearance is an issue switch to opposite tensioner kit and assemble as shown (Fig. 3Ud).

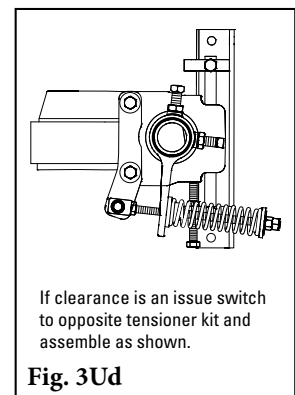
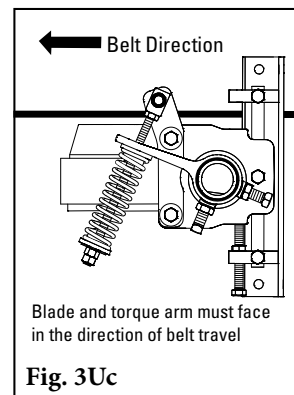
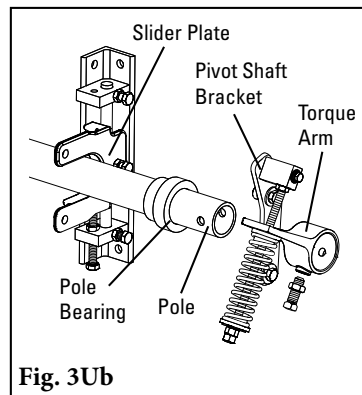
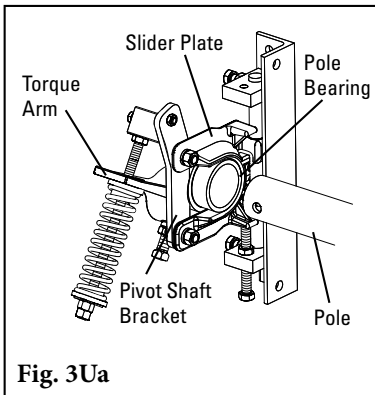

4U. Tighten adjusting arm set screws.

- Spring tensioner nuts should be moved near the end of the threaded rod. Insert a screwdriver or small rod through holes on end of cleaner pole. Rotate cleaner blade into a position parallel to belt. Blade should not be touching belt at this time. The gap between the torque arm and pivot block should be approximately 2" (Fig. 4Ua).
- Tighten torque arm set screws and lock nuts on both sides of cleaner with the blade held parallel to the belt. Release the screw driver to let the blade pivot away from the belt. Tighten spring tensioner nuts until blade is pivoted back to being parallel with the belt. The torque arm should not touch the pivot block (Fig. 4Ub).

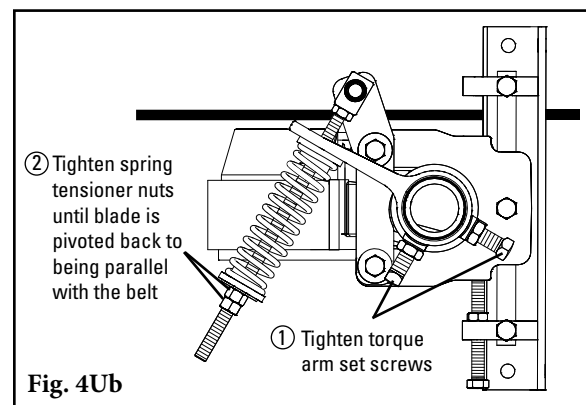
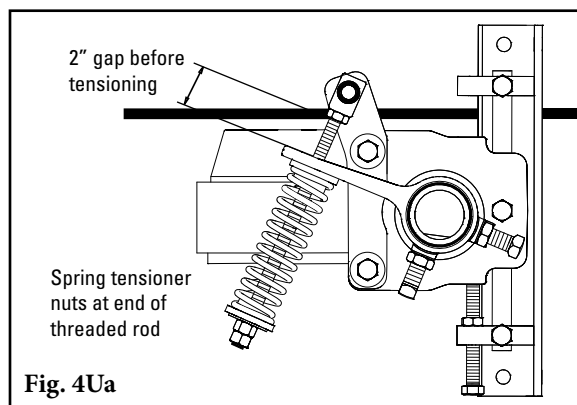

Section 4 - Installation Instructions (cont.)

5U. Adjust the blade to the belt.

- Loosen slide plate set screws and lock nuts. Adjust by turning adjusting bolts either up or down (Fig. 5U).
- Adjust blade either up or down until both blade ends and the center make full contact with belt.

IMPORTANT: In some cases, due to irregular belt wear or cupping, it may be necessary to make final adjustments independently on both sides.

- Tighten lock nuts on adjusting bolts to secure blade in correct position. Also tighten slide plate set screws and lock nuts.

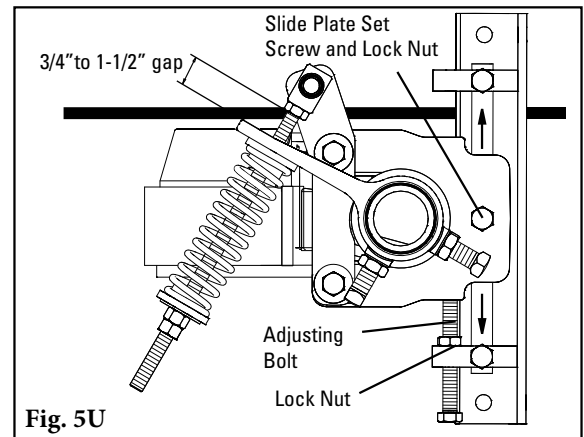

Fig. 5U

Spring Length Chart (for Cleaners with USTensioners)								
Blade Width	Purple Spring		Silver Spring		White Spring			
	in.	mm	in.	mm	in.	mm	in.	mm
18	450	6 1/8	154	6 3/8	160	6 3/8	162	
24	600	5 7/8	148	6 1/4	148	6 1/4	160	
30	750	5 1/2	140	6 1/8	156	6 1/4	158	
36	900	5 3/8	136	6	152	6 1/8	156	
42	1050	5	128	5 7/8	150	6 1/8	154	
48	1200	N/A	N/A	5 3/4	146	6	152	
54	1350	N/A	N/A	5 5/8	142	5 7/8	150	
60	1500	N/A	N/A	5 1/2	140	5 7/8	150	
72	1800	N/A	N/A	N/A	N/A	5 1/2	140	
84	2100	N/A	N/A	N/A	N/A	5 3/8	136	

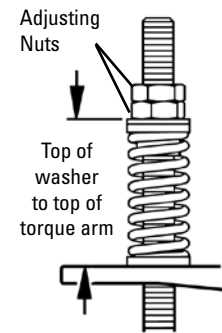

Fig. 6U

6U. Set the blade tension.

- Set spring length to determined length (Fig. 6U). **IMPORTANT:** Always be sure there is uniform contact between blade and belt.
- If blade is not in full contact with belt at edges and center, either raise or lower pole position of cleaner and reapply tension.
- Please note, when fully tensioned there should be approximately 3/4" to 1-1/2" of space between the torque arm and pivot block (Fig. 5U).

J-Bolt Tensioner Instructions - For Stainless Steel Cleaners

2J. Install the mounting brackets onto the structure.

- Using a square, lightly raise return side belt (take out cupping or sagging on edges) to find belt's true parallel path to the structure; and mark reference point #1 on the structure on both sides of the conveyor. Measure down 3-3/8" (84mm) from reference point #1 on both sides and mark reference point #2 (Fig. 2Ja).
- Position the mounting brackets so the centerline marks on the brackets are in line with reference points #2 on the structure (Fig. 2Jb).
- Clamp or weld into position.

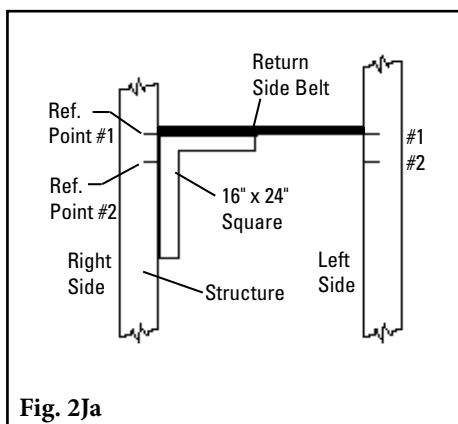

Fig. 2Ja

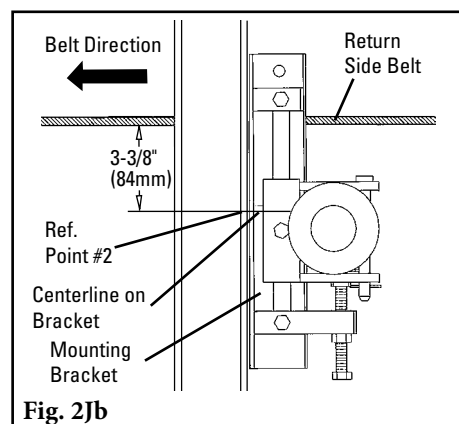
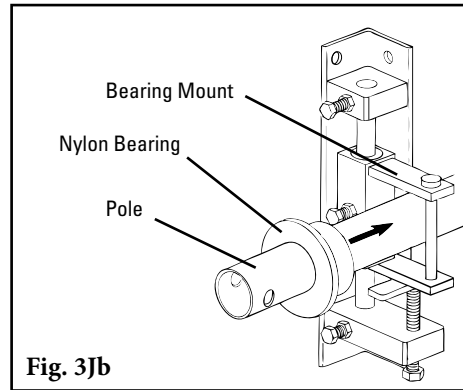
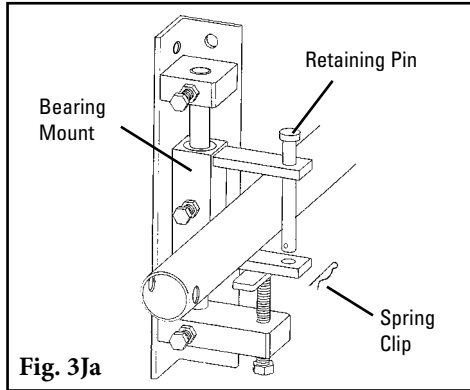

Fig. 2Jb

Section 4 - Installation Instructions (cont.)

3J. Install cleaner pole into bearing mounts in both mounting brackets.

- Remove nylon bearings from both bearing mounts. Remove spring clip and pull retaining pin out of one bearing mount. Slide cleaner pole into bearing mount on the opposite side and then position it into bearing mount where retaining pin was removed. Reinsert retaining pin and lock into place with spring clip (Fig. 3Ja).
- Slide a nylon bearing onto each pole end with flanged end facing away from belt. Nylon bearing will fit snugly into bearing mount (Fig. 3Jb).
- Position the pole so that blade is centered to belt. With blade centered, draw a line around pole at nylon bearing. This line can be used as a reference point to ensure the pole/blade remains centered to belt while other steps are completed.



4J. Install the stop collars.

- Slide one stop collar onto the most convenient pole end (Fig. 4Ja).
- Insert a screwdriver or small rod into hole on end of cleaner pole. Pushing on the rod, move blade into a position parallel to belt (Fig. 4Jb). Blade should not be touching belt at this time.
- Tighten stop collar set screw and lock nut to hold blade parallel to belt.
- Install second stop collar on other pole end. Do not tighten set screw and lock nut at this time.

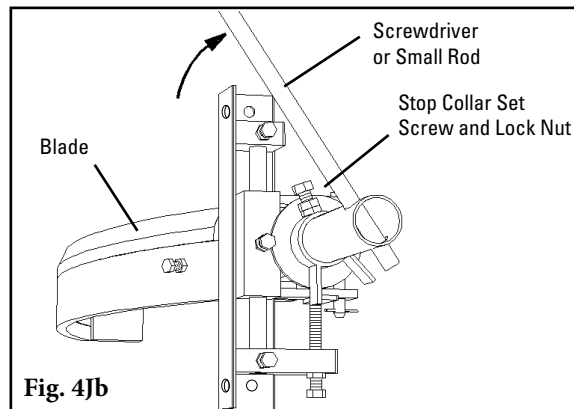
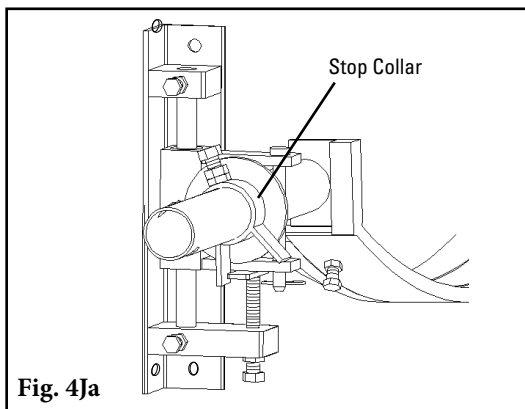

5J. Adjust blade to belt.

- Loosen bearing mount set screws and lock nuts. Adjustments will be made by turning adjusting bolts either up or down (Fig. 5J).
- Adjust blade either up or down until both blade ends and the center make full contact with belt.
IMPORTANT: In some cases, due to irregular belt wear or cupping, it may be necessary to make final adjustments independently on both sides.
- Tighten lock nuts on adjusting bolts to secure blade in correct position. Also tighten bearing mount set screws and lock nuts.

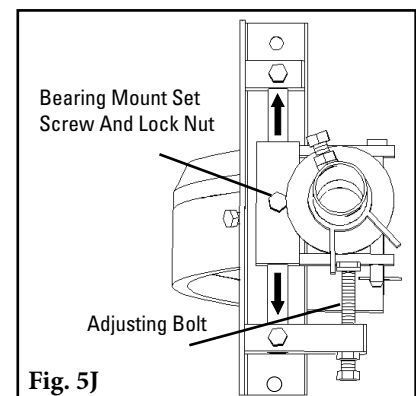

Section 4 - Installation Instructions (cont.)

6J. Mount the tensioning system.

- Slide one adjusting arm onto pole end with stop collar that was not tightened (Fig. 6Ja).
- Assemble tension spring and J-bolt mount to adjusting arm. Locate position for J-bolt mount (Fig. 6Jb).
IMPORTANT: Allow at least 2" (50mm) of upward movement for J-bolt end for future adjustment.
- The J-bolt mount can be mounted in any position (360 degrees) around pole. The only requirement is that J-bolt and spring remain perpendicular to adjusting arm (Fig. 6Jc).
- Weld or bolt J-bolt mount into position.
- Tighten adjusting arm set screw and lock nut to secure position on pole.
- Adjust J-bolt to apply light tension on tension spring.

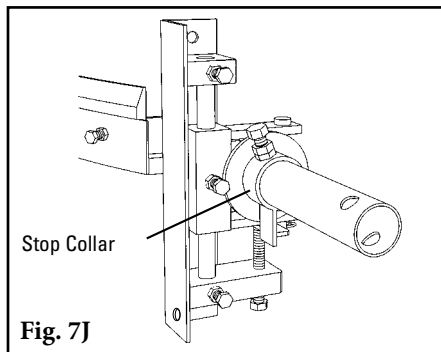
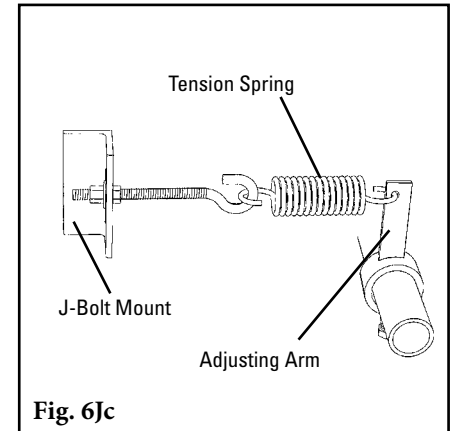
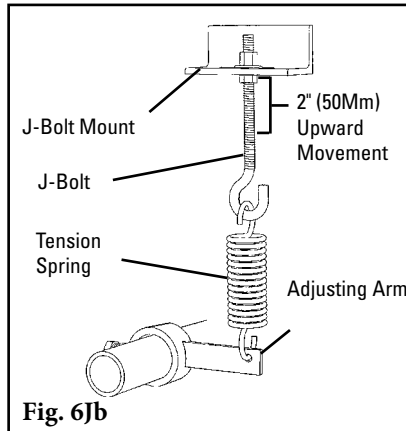
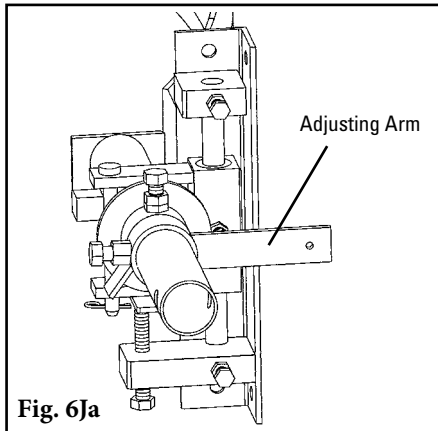

7J. Set up stop collar and assemble opposite tensioning system.

- Loosen stop collar (Fig. 7J).
- Slide the second adjusting arm on pole end; assemble and mount tensioning system.

8J. Set the spring tension.

- Loosen J-bolt jam nuts and turn tensioner adjusting nuts until both springs have a clearance of about .030" between all coils (use Spring Tension Gauge included in installation instruction packet.) (Fig. 8J).
IMPORTANT: Always be sure there is uniform contact between blade and belt.
- If blade is not in full contact with belt at edges and center, either raise or lower pole position of cleaner and reapply tension.

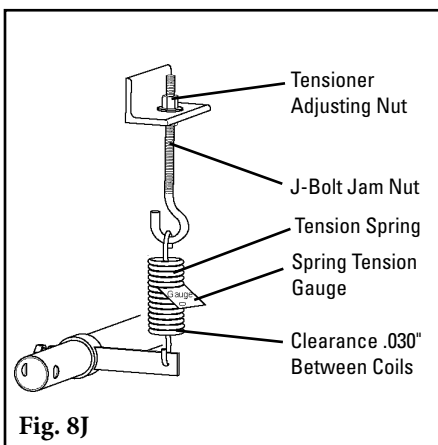

9J. Set the blade travel stop.

Set both stop collars to a clearance of 1/4" (6mm) for UV and UC cleaners, or 1/2" (13mm) for UF cleaners, from bearing mount stops (Fig. 9J). This is to prevent blade from moving into belt. Tighten set screws and lock nuts.

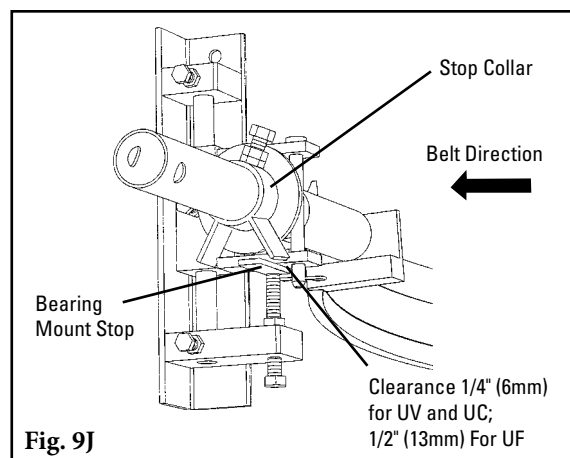

Section 5 - Pre-Operation Checklist and Testing

5.1 Pre-Op Checklist

- Recheck that all fasteners are tightened properly
- Add pole caps
- Apply all supplied labels to the cleaner
- Check the blade location on the belt
- Be sure that all installation materials and tools have been removed from the belt and the conveyor area

5.2 Test Run the Conveyor

- Run the conveyor for at least 15 minutes and inspect the cleaning performance
- Check the tensioner spring for recommended length (proper tensioning)
- Make adjustments as necessary

NOTE: Observing the cleaner when it is running and performing properly will help to detect problems or when adjustments are needed later.

Section 6 - Maintenance

Flexco belt cleaners are designed to operate with minimum maintenance. However, to maintain superior performance some service is required. When the cleaner is installed a regular maintenance program should be set up. This program will ensure that the cleaner operates at optimal efficiency and problems can be identified and fixed before the cleaner stops working.

All safety procedures for inspection of equipment (stationary or operating) must be observed. The U-Type® Belt Cleaner operates at the discharge end of the conveyor and is in direct contact with the moving belt. Only visual observations can be made while the belt is running. Service tasks can be done only with the conveyor stopped and by observing the correct lockout/tagout procedures.

6.1 New Installation Inspection

After the new cleaner has run for a few days a visual inspection should be made to ensure the cleaner is performing properly. Make adjustments as needed.

6.2 Routine Visual Inspection (every 2-4 weeks)

A visual inspection of the cleaner and belt should look for:

- If spring length is the correct length for optimal tensioning
- If spring gap is correct for optimal tensioning (for J-Bolt tensioners)
- If belt looks clean or if there are areas that are dirty
- If blade is worn out and needs to be replaced
- If there is damage to the blade or other cleaner components
- If fugitive material is built up on cleaner or in the transfer area
- If there is cover damage to the belt
- If there is vibration or bouncing of the cleaner on the belt
- If a snub pulley is used, a check should be made for material buildup on the pulley
- Significant signs of carryback

If any of the above conditions exist, a determination should be made on when the conveyor can be stopped for cleaner maintenance.

6.3 Routine Physical Inspection (every 6-8 weeks)

When the conveyor is not in operation and properly locked and tagged out, a physical inspection of the cleaner to perform the following tasks:

- Clean material buildup off of the cleaner blade and pole
- Closely inspect the blade for wear and any damage. Replace if needed.
- Ensure full blade to belt contact
- Inspect the cleaner pole for damage
- Inspect all fasteners for tightness and wear. Tighten or replace as needed.
- Replace any worn or damaged components
- Check the tension of the cleaner blade to the belt. Adjust the tension if necessary using the chart on the cleaner or the one on Page 15. For J-bolt Tensioners, use the spring tension gauge to set a .030" (.7mm) gap between spring coils.
- When maintenance tasks are completed, test run the conveyor to ensure the cleaner is performing properly

Section 6 - Maintenance

6.4 Blade Replacement Instructions

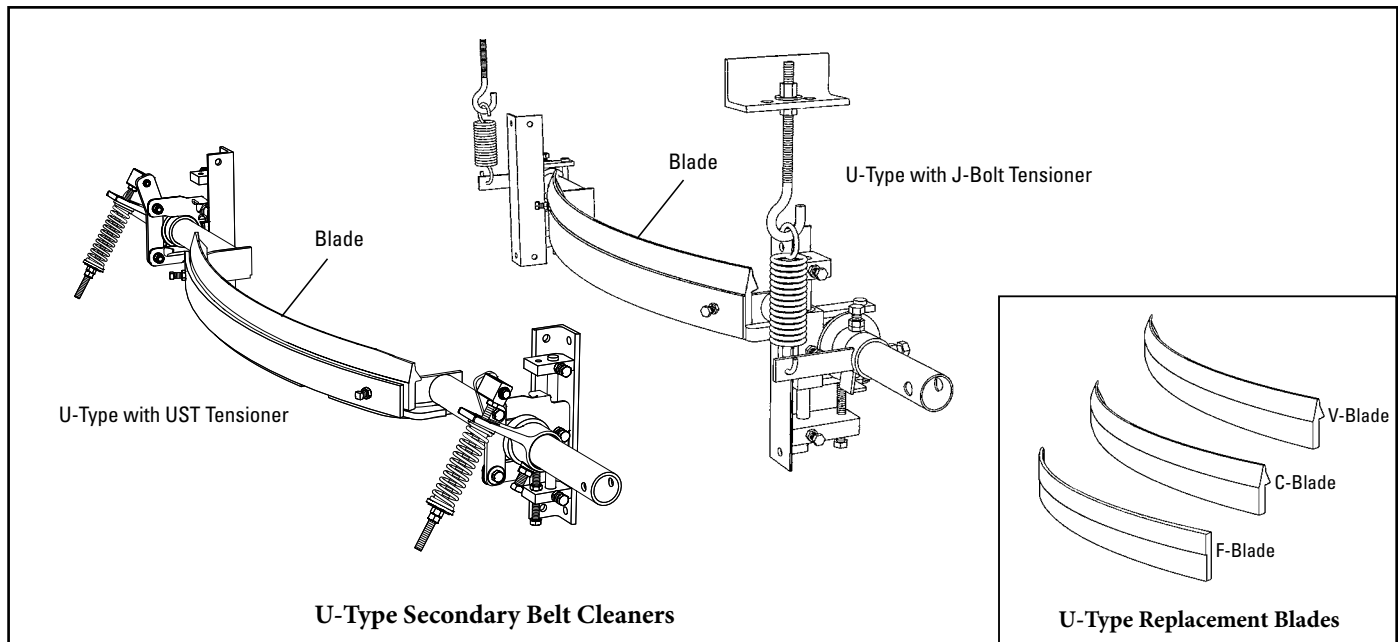

Physically lock out and tag the conveyor at the power source before you begin cleaner installation.

Tools Needed:

- Tape measure
- 3/4" (19mm) wrench
- Wire brush

Double check the blade type needed for your application:

F- Blade - for mechanically-spliced belts

C-Blade - for Flexco Solid Plate mechanically spliced and vulcanized belts

V-Blade - for vulcanized belts. Can be used with mechanical splices (solid bolt fasteners) that are recessed (skived) into the belt cover (bolts must be ground on plate fasteners)

1. Release the blade tension.

UST Spring Tensioner: Loosen the tension adjusting nuts on the tensioner pivot rods, allowing the pole to rotate the blade down (Fig. 1a).

J-Bolt Tensioner: Loosen both J-bolt jam nuts and remove the tensioner adjusting nuts and flat washers, allowing the pole to rotate against the stop collar and the blade to rotate down (Fig. 1b).

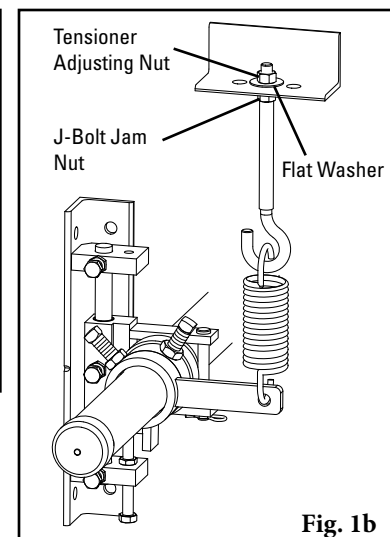
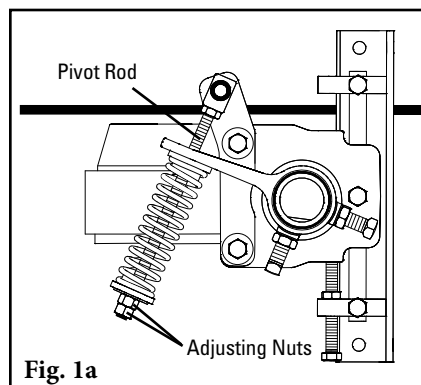

Section 6 - Maintenance

2. Remove the worn blade.

- Loosen both locknuts on the blade retaining screws. Turn blade retaining screws out 8 turns (Fig. 2a).
- From one end, insert a screwdriver under the blade and lightly pry the blade up and out of the blade holder (Fig. 2b). Once the blade breaks free, pull it out by hand.
- Remove the blade from the holder and clean material buildup from holder with a wire brush (Fig. 2c).

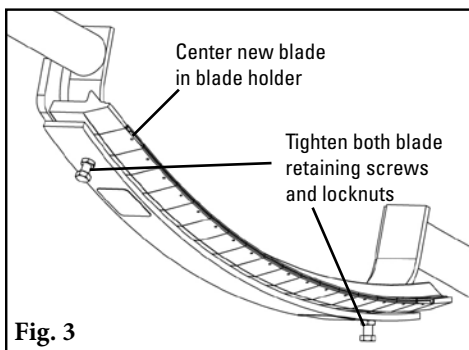
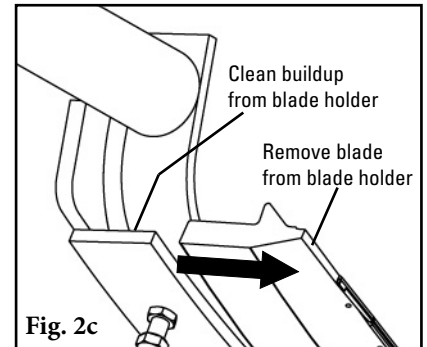
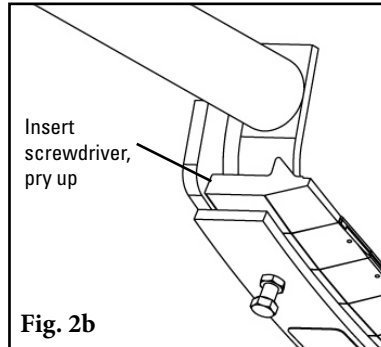
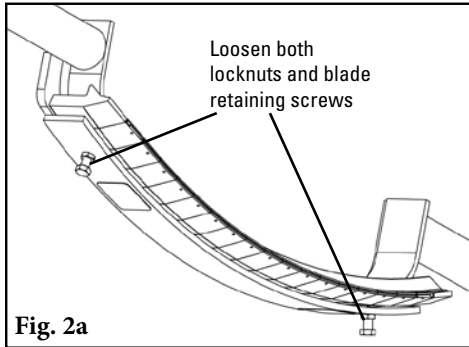

3. Install the new blade.

- Center the blade in the holder (Fig. 3).
- Tighten blade retaining screws 8 turns and tighten the blade retaining screw locknuts (Fig 3).

Spring Length Chart (for Cleaners with USTensioners)							
Blade Width		Purple Spring		Silver Spring		White Spring	
in.	mm	in.	mm	in.	mm	in.	mm
18	450	6 1/8	154	6 3/8	160	6 3/8	162
24	600	5 7/8	148	6 1/4	148	6 1/4	160
30	750	5 1/2	140	6 1/8	156	6 1/4	158
36	900	5 3/8	136	6	152	6 1/8	156
42	1050	5	128	5 7/8	150	6 1/8	154
48	1200	N/A	N/A	5 3/4	146	6	152
54	1350	N/A	N/A	5 5/8	142	5 7/8	150
60	1500	N/A	N/A	5 1/2	140	5 7/8	150
72	1800	N/A	N/A	N/A	N/A	5 1/2	140
84	2100	N/A	N/A	N/A	N/A	5 3/8	136

4. Reset the blade tension.

UST Spring Tensioner: Refer to the chart for the spring length required for the belt width. Lightly pull the pivot arm toward the end of the torque arm slot nearest the pole and turn the adjusting nuts until the required spring length is achieved (Fig. 4a). **NOTE:** The chart is also on the cleaner's pivot shaft bracket for future reference for retensioning maintenance.

J-Bolt Tensioner: Rotate the pole and insert the J bolts through the J bolt mount holes and install the flat washers and tensioner adjusting nuts. Turn the tensioner adjusting nuts until a .030" gap (use Spring Tension Gauge included with cleaner) appears between all coils of the tension spring (Fig. 4b). Lock both J bolt jam nuts.

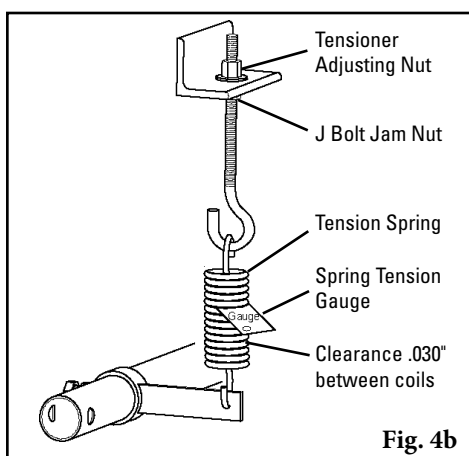

- Inspect for full blade contact to the belt.** Important - Always be sure there is uniform contact between the blade and the belt. If the blade is not in full contact with the belt at the edges and center, raise or lower the pole position of the cleaner and reapply the tension (See Installation Instructions).

Test run the cleaner. Run the conveyor for at least 15 minutes and inspect the cleaning performance. Check the spring length for proper tensioning. Make adjustments as necessary.

Section 6 - Maintenance

6.5 Maintenance Log

Conveyor Name/No. _____

Date: _____ Work done by: _____ Service Quote # _____

Activity: _____

Date: _____ Work done by: _____ Service Quote # _____

Activity: _____

Date: _____ Work done by: _____ Service Quote # _____

Activity: _____

Date: _____ Work done by: _____ Service Quote # _____

Activity: _____

Date: _____ Work done by: _____ Service Quote # _____

Activity: _____

Date: _____ Work done by: _____ Service Quote # _____

Activity: _____

Date: _____ Work done by: _____ Service Quote # _____

Activity: _____

Section 6 - Maintenance

6.6 Cleaner Maintenance Checklist

Belt Cleaner: _____ **Serial Number:** _____

Beltline Information:

Beltline Number: _____ Belt Condition: _____

Belt Width: 18" 24" 30" 36" 42" 48" 54" 60" 72" 84"
(450mm) (600mm) (750mm) (900mm) (1050mm) (1200mm) (1350mm) (1500mm) (1800mm) (2100mm)

Head Pulley Diameter (*Belt & Lagging*): _____ Belt Speed: _____ fpm Belt Thickness: _____

Belt Splice _____ Condition of Splice _____ Number of splices _____ Skived Unskived

Material conveyed _____

Days per week run _____ Hours per day run _____

Blade Life:

Date blade installed: _____ Date blade inspected: _____ Estimated blade life: _____

Is blade making complete contact with belt? Yes No

Distance from wear line: LEFT _____ MIDDLE _____ RIGHT _____

Blade condition: Good Grooved Smiled Not contacting belt Damaged

Measurement of spring: Required _____ Currently _____

Was Cleaner Adjusted: Yes No

Pole Condition: Good Bent Worn

Lagging: Slide lag Ceramic Rubber Other None

Condition of lagging: Good Bad Other _____

Cleaner's Overall Performance: (Rate the following 1 - 5, 1=very poor - 5= very good)

Appearance: Comments: _____

Location: Comments: _____

Maintenance: Comments: _____

Performance: Comments: _____

Other Comments: _____



Section 7 - Troubleshooting

Problem	Possible Cause	Possible Solutions
Vibration	Cleaner secure bolts not set	Ensure all locking nuts are tight (Loctite)
	Cleaner not set up correctly	Ensure cleaner set up properly (1°-3° into belt)
	Belt tension too high	Ensure cleaner can conform to belt, or replace with alternate Flexco secondary cleaner
	Belt flap	Introduce hold-down roller to flatten belt
	Cleaner over-tensioned	Ensure cleaner is correctly tensioned
	Cleaner under-tensioned	Ensure cleaner is correctly tensioned
	Nylon bearing worn out or missing	Replace nylon bearing
Material buildup on cleaner	Cleaner not set up correctly	Ensure cleaner set up properly (1°-3° into belt)
	Buildup on chute	Ensure cleaner is not located too close to back of chute, allowing buildup
	Cleaner being overburdened	Introduce Flexco precleaner
	Excessive sticky material	Frequently clean unit of buildup
Damaged belt cover	Cleaner over-tensioned	Ensure cleaner is correctly tensioned
	Cleaner blade damage	Check blade for wear, damage and chips, replace where necessary
	Attack angle not correct	Ensure cleaner set up properly (1°-3° into belt)
	Material buildup in chute	Frequently clean unit of buildup
Cleaner not conforming to belt	Cleaner not set up correctly	Ensure cleaner set up properly (1°-3° into belt)
	Belt tension too high	Ensure cleaner can conform to belt, or replace with alternate Flexco secondary cleaner
	Belt flap	Introduce hold-down roller to flatten belt
	Cleaner cannot conform	Ensure cleaner can conform to belt, or replace with alternate Flexco secondary cleaner
Material passing cleaner	Cleaner not set up correctly	Ensure cleaner set up properly (1°-3° into belt)
	Cleaner tension too low	Ensure cleaner is correctly tensioned
	Cleaner blade worn/damaged	Check blade for wear, damage and chips, replace where necessary
	Cleaner being overburdened	Introduce Flexco precleaner
	Belt flap	Introduce hold-down roller to flatten belt
	Cleaner cannot conform	Ensure cleaner can conform to belt, or replace with alternate Flexco secondary cleaner
	Blade in backwards	Install blade correctly and set correct tension
Damage to mechanical fastener	Incorrect cleaner blade selection	Change blade type to accommodate fastener style (UC or UF)
	Belt not skived correctly	Spot and redo splice correctly, lowering the profile flush or below belt surface
Missing material in belt center only	Cleaner pole located too high	Ensure cleaner set up properly (1°-3° into belt)
	Cleaner blade worn/damaged	Check blade for wear, damage and chips, replace where necessary
Missing material on outer edges only	Cleaner pole located too low	Ensure cleaner set up properly (1°-3° into belt)
	Cleaner blade worn/damaged	Check blade for wear, damage and chips, replace where necessary

Section 8 - Specs and CAD Drawings

8.1 Specs and Guidelines

Pole Length Specifications					
Cleaner Size		Pole Length		Maximum Conveyor Span	
in.	mm	in.	mm	in.	mm
18	450	64	1600	54	1350
24	600	70	1750	60	1500
30	750	76	1900	66	1650
36	900	82	2050	72	1800
42	1050	88	2200	78	1950
48	1200	94	2350	84	2100
54	1350	100	2500	90	2250
60	1500	106	2650	96	2400
72	1800	124	3100	114	2850
84	2100	136	3400	126	3150

Pole Diameter - 18" to 60" cleaners: 2-3/8" (60mm)

Pole Diameter - 72" and 84" cleaners: 2-7/8" (75mm)

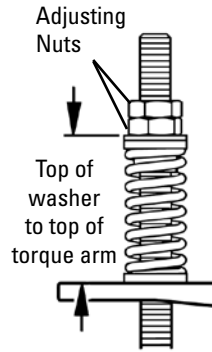
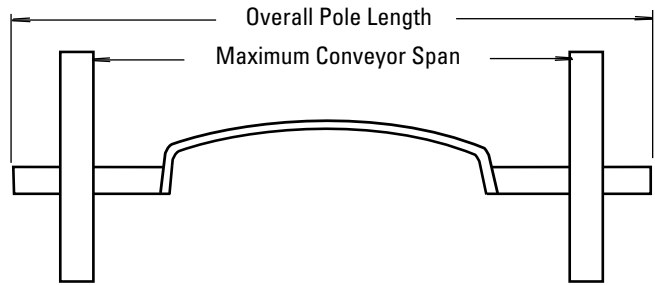

Spring Length Chart (For Cleaners with UST Tensioners)							
Blade Width		Purple Spring		Silver Spring		White Spring	
in.	mm	in.	mm	in.	mm	in.	mm
18	450	6 1/8	154	6 3/8	160	6 3/8	162
24	600	5 7/8	148	6 1/4	148	6 1/4	160
30	750	5 1/2	140	6 1/8	156	6 1/4	158
36	900	5 3/8	136	6	152	6 1/8	156
42	1050	5	128	5 7/8	150	6 1/8	154
48	1200	N/A	N/A	5 3/4	146	6	152
54	1350	N/A	N/A	5 5/8	142	5 7/8	150
60	1500	N/A	N/A	5 1/2	140	5 7/8	150
72	1800	N/A	N/A	N/A	N/A	5 1/2	140
84	2100	N/A	N/A	N/A	N/A	5 3/8	136

Clearance Guidelines for Installation							
U Cleaner Size		Clearance		U Cleaner Size		Clearance	
in.	mm	in.	mm	in.	mm	in.	mm
18	450	5 1/2	140	48	1200	9 1/2	242
24	600	6 1/2	166	54	1350	9 1/2	242
30	750	7 1/2	191	60	1500	9 1/2	242
36	900	7 1/2	171	72	1800	10 1/4	261
42	1050	8 1/2	217	84	2100	10 1/4	261

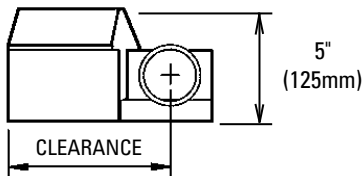

Spring Tensioner Guidelines (For Stainless Steel Cleaners with J-Bolt Tensioners)

- Spring gap = .030" (.7mm)
- * Gauge provided

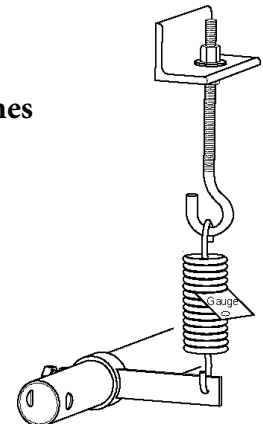

Specifications:

- Maximum Belt Speed..... 1300 FPM (6.6M/sec); F-Blade - 1000 FPM (5M/sec)
- Temperature Rating..... -30°F to 180°F (-35°C to 82°C)
- Useable Blade Wear Length..... V-Blade and C-Blade - 3/8" (9mm); F-Blade - 1 3/4" (44mm)
- Available for Belt Widths..... 18" to 84" (450 to 2100mm).

Other sizes available upon request.



Section 8 - Specs and CAD Drawings

8.3 CAD Drawing - Cleaners with J-Bolt Tensioners

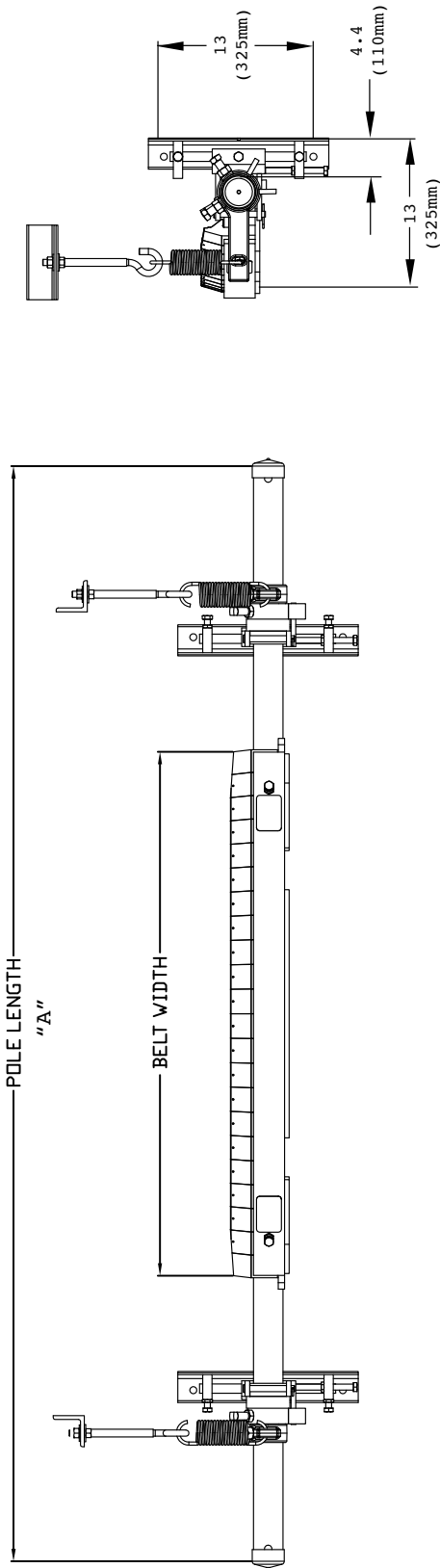

J-BOLT U-TYPE STAINLESS STEEL V-BLADE IMPERIAL MOUNTING FASTENERS		J-BOLT U-TYPE STAINLESS STEEL C-BLADE IMPERIAL MOUNTING FASTENERS	
C LEANER	"A"	C LEANER	"A"
77273	18" (450MM)	77395	18" (450MM)
77274	24" (600MM)	77396	24" (600MM)
77275	30" (750MM)	77397	30" (750MM)
77276	36" (900MM)	77398	36" (900MM)
77277	42" (1050MM)	77399	42" (1050MM)
77278	48" (1200MM)	77400	48" (1200MM)
77279	54" (1350MM)	77401	54" (1350MM)
77280	60" (1500MM)	77402	60" (1500MM)
77281	72" (1800MM)	77403	72" (1800MM)
77282	84" (2100MM)	77404	84" (2100MM)

Section 9 - Replacement Parts

9.1 Replacement Parts List - U-Type with UST Tensioners

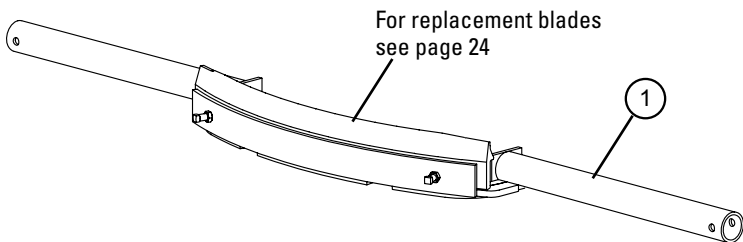

Replacement Parts- Poles				
Ref	Description	Ordering Number	Item Code	Wt. Lbs.
1	18" (450mm) Pole	USP18/450	76772	40.8
	24" (600mm) Pole	USP24/600	76773	44.2
	30" (750mm) Pole	USP30/750	76774	47.6
	36" (900mm) Pole	USP36/900	76775	51.1
	42" (1050mm) Pole	USP42/1050	76776	54.5
	48" (1200mm) Pole	USP48/1200	76777	57.9
	54" (1350mm) Pole	USP54/1350	76778	61.4
	60" (1500mm) Pole	USP60/1500	76779	64.8
	72" (1800mm) Pole	USP72/1800	76780	71.6
	84" (2100mm) Pole	USP84/2100	76781	78.5

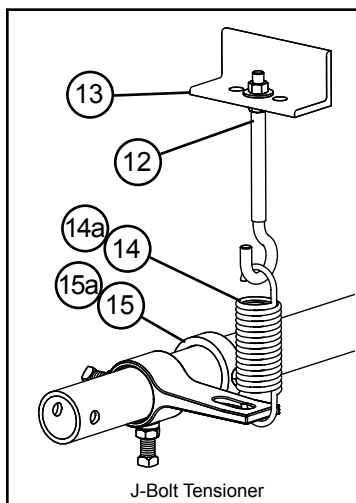
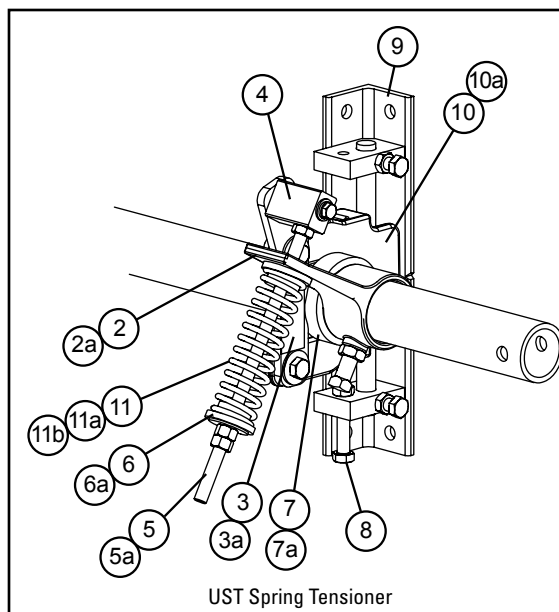

For use in changing UST Spring Tensioner to a J-Bolt Tensioner

Replacement Parts- J-bolt Tensioner				
Ref	Description	Ordering Number	Item Code	Wt. Lbs.
12	J-Bolt (incl. locknut and washer)	STJK	74417	0.7
13	J-Bolt Mount (1 ea.)	STJM	74775	3.0
14	Tension Spring (1 ea.) †	STTS	74419	1.4
14a	HD Tension Spring (1 ea.) §	HDS	74502	2.0
15	Pole Lock Collar †	EZP1PL	75641	1.1
15a	HD Pole Lock Collar §	MSPPL	75816	1.9
—	J-Bolt Tensioner Kit † (Optional) (incl. 2 ea. items 12, 13, 14, 15)	UBTK	76977	4.7
—	HD J-Bolt Tensioner Kit § (Optional) (incl. 2 ea. items 12, 13, 14a, 15a)	UHDBTK	76978	5.2

† Standard components for blade widths 18"-60" (450-1500mm)
 § HD components for blade widths 72"-84" (1800-2100mm)

Replacement Parts- UST Tensioners				
Ref	Description	Ordering Number	Item Code	Wt. Lbs.
2	Torque Arm Kit* (1 ea.) †Δ	ESTAK-EST	76406	3.6
2a	Torque Arm Kit HD* (1 ea.) §	PSTA	75896	11.4
3	Pivot Shaft Bracket Kit* (1 ea.) †Δ	UPSBK	76784	1.7
3a	Pivot Shaft Bracket Kit HD* (1 ea.) §	QMTPSBK	76099	4.3
4	Pivot Block Kit* (1 ea.) †Δ	UPBK	76785	1.0
5	Pivot Rod Kit* (1 ea.) †Δ	ESPRK	76409	1.2
5a	Pivot Rod Kit HD* (1 ea.) §	QMTPAK	76096	4.3
6	Bushing Kit (incl. 2 bushings) †Δ	ESBK-PS	76410	0.1
6a	Bushing Kit HD (incl. 2 bushings) §	QMTBK-W	76098	0.1
7	Standard Pole Bearing (1 ea.) †Δ	USPB	76786	0.2
7a	HD Pole Bearing (1 ea.) §	UHPB	76787	0.3
8	Adjusting Bolt Kit (1 ea.) (incl. locknut)	ABU	76788	0.2
9	Mounting Bracket Kit* (1 ea.)	UMBK	76789	9.7
10	Slide Plate Kit* (1 ea.) †Δ	USPK	76790	4.6
10a	HD Slide Plate Kit* (1 ea.) §	UHSPK	76791	5.2
11	Tension Spring - Purple (1 ea.) †	QMTS-P	75845	0.6
11a	Tension Spring - Silver (1 ea.) Δ	ESS-S	76412	1.2
11b	Tension Spring - White (1 ea.) §	PSTS-W	75898	1.7
—	UST Spring Tensioner* - Purple † (incl. 1 ea. items 2, 3, 4, 5, 6, 8, 9, 10, 11)	UST-P	76794	21.0
—	UST Spring Tensioner* - Silver Δ (incl. 1 ea. items 2, 3, 4, 5, 6, 8, 9, 10, 11a)	UST-S	76795	21.0
—	UST Spring Tensioner* - White § (incl. 1 ea. items 2a, 3a, 4, 5a, 6a, 8, 9, 10a, 11b)	UST-W	77757	28.9
—	Standard Mounting Kit* (incl. 1 ea. items 8, 9, 10) † Δ (for blade widths 18"- 60" (450 - 1500mm))	USMK	76792	14.6
—	HD Mounting Kit* (incl. 1 ea. items 8, 9, 10a) § (for blade widths 72"- 84" (1800 - 2100mm))	UHMK	76793	15.5

*Hardware included
 † Standard components for blade widths 18"-42" (450-1050mm)
 Δ Standard components for blade widths 48"-60" (1200-1500mm)
 § HD components for blade widths 72"-84" (1800-2100mm)

Section 9 - Replacement Parts

9.2 Replacement Parts List - Stainless Steel U-Type with J-Bolt Tensioners

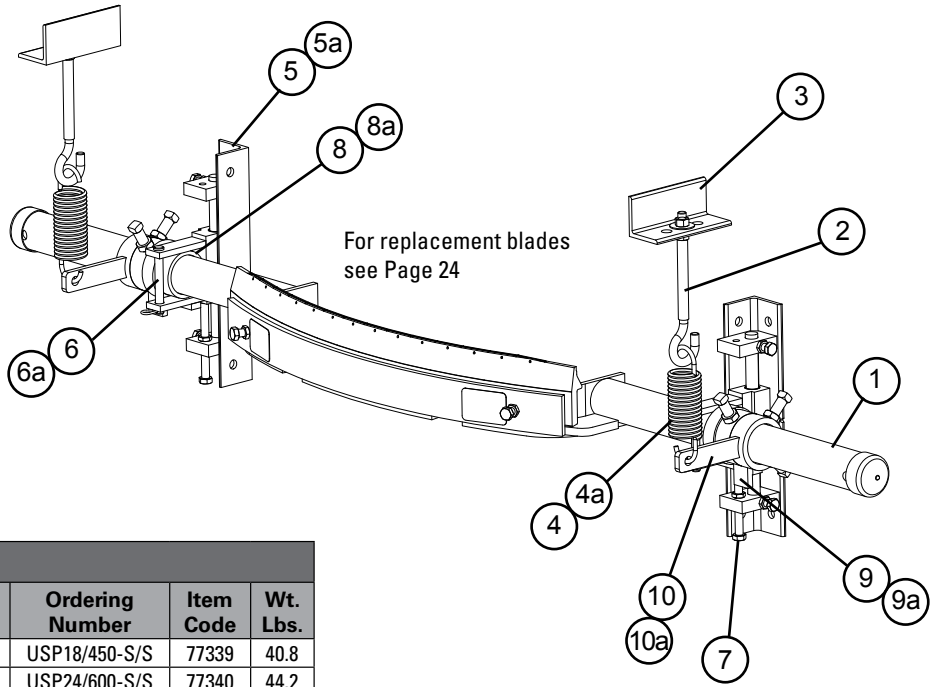

U-Type Replacement Parts				
Ref	Description	Ordering Number	Item Code	Wt. Lbs.
1	18" (450mm) Pole	USP18/450-S/S	77339	40.8
	24" (600mm) Pole	USP24/600-S/S	77340	44.2
	30" (750mm) Pole	USP30/750-S/S	77341	47.6
	36" (900mm) Pole	USP36/900-S/S	77342	51.1
	42" (1050mm) Pole	USP42/1050-S/S	77343	54.5
	48" (1200mm) Pole	USP48/1200-S/S	77344	57.9
	54" (1350mm) Pole	USP54/1350-S/S	77345	61.4
	60" (1500mm) Pole	USP60/1500-S/S	77347	64.8
	72" (1800mm) Pole	USP72/1800-S/S	77349	71.6
84" (2100mm) Pole	USP84/2100-S/S	77351	78.5	
2	J-Bolt Kit* (incl. locknut and washer)	STJK-S/S	77334	0.7
3	J-Bolt Mount (1 ea.)	STJM-S/S	77332	3.0
4	18 - 60" Tension Spring (1 ea.)	STTS-S/S	75585	1.0
4a	72" Tension Spring (1 ea.)	HDTS-S/S	75586	1.5
5	18 - 60" Mounting Bracket Kit (incl. R & L)	MBKUJ-S/S	77359	16.0
5a	72" Mounting Bracket Kit (incl. R & L)	MBKUJH-S/S	77360	19.0
6	18 - 60" Retaining Pin & Spring Clip	RPU-S/S	77361	1.0
6a	72" Retaining Pin & Spring Clip	HDRPU-S/S	77362	1.5
7	Adjusting Bolt Kit (incl. locknut)	ABU	76788	1.0
8	18 - 60" UHMW Bearing (1 ea.)	USPB	76786	1.0
8a	72" UHMW Bearing (1 ea.)	UHPB	76787	1.0
9	18 - 60" Stop Collar* (1 ea.)	SCU60-S/S	77363	2.0
9a	72" Stop Collar* (1 ea.)	SCUHD-S/S	77333	2.0
10	18 - 60" Adjusting Arm* (1 ea.)	HARK-S/S	77364	2.0
10a	72" Adjusting Arm* (1 ea.)	HDLARK-S/S	77331	2.0
-	18 - 60" Mounting Kit* (incl. 2 ea. items 2, 3, 4, 5, 6, 7, 8, 9 & 10)	MKU-S/S	77373	40.0
-	72" Mounting Kit* (incl. 2 ea. items 2, 3, 4a, 5a, 6a, 7, 8a, 9a & 10a)	MKUHD-S/S	77374	43.0

*Hardware included
Lead time: 1 working day

Section 9 - Replacement Parts

9.3 Replacement Blades

U-Type V-Blades (Tungsten Carbide)*				
Belt Width		Ordering Number	Item Code	Wt. Lbs.
in.	mm			
18	450	URVB18/450	76736	5.0
24	600	URVB24/600	76737	6.7
30	750	URVB30/750	76738	8.4
36	900	URVB36/900	76739	10.1
42	1050	URVB42/1050	76740	11.7
48	1200	URVB48/1200	76741	13.5
54	1350	URVB54/1350	76742	15.0
60	1500	URVB60/1500	76743	16.8
72	1800	URVB72/1800	76744	20.2
84	2100	URVB84/2100	76745	23.5

*NOTE: V-Blades (Tungsten Carbide) can be used on vulcanized belts and mechanically spliced belts ONLY IF the splice is skived (recessed into the belt's cover) (on solid plate splices the bolts must be ground).
 CAUTION: The V-Blade CANNOT be used on belts with mechanical rip repair fasteners. Use the F-Blade.

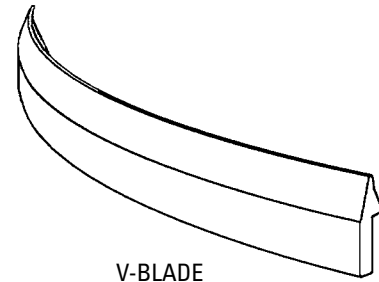

V-BLADE

U-Type C-Blades (Impact Resistant Tungsten Carbide)*				
Belt Width		Ordering Number	Item Code	Wt. Lbs.
in.	mm			
18	450	URCB18/450	76748	5.0
24	600	URCB24/600	76749	6.7
30	750	URCB30/750	76750	8.4
36	900	URCB36/900	76751	10.1
42	1050	URCB42/1050	76752	11.7
48	1200	URCB48/1200	76753	13.5
54	1350	URCB54/1350	76754	15.0
60	1500	URCB60/1500	76755	16.8
72	1800	URCB72/1800	76756	20.2
84	2100	URCB84/2100	76757	23.5

*NOTE: C-Blades can be used on Flexco® Solid Plate, mechanically fastened and vulcanized belts.

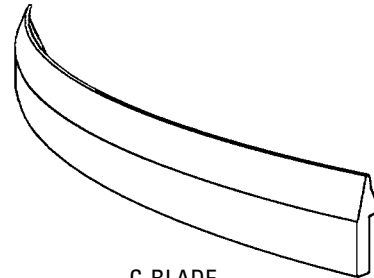

C-BLADE

U-Type F-Blades (Urethane)*				
Belt Width		Ordering Number	Item Code	Wt. Lbs.
in.	mm			
18	450	UFB18	74448	3.0
24	600	UFB24	74449	4.0
30	750	UFB30	74450	5.0
36	900	UFB36	74451	6.0
42	1050	UFB42	74452	7.0
48	1200	UFB48	74453	8.0
54	1350	UFB54	74454	9.0
60	1500	UFB60	74455	10.0
72	1800	UFB72	74456	12.0
84	2100	UFB84	74460	14.0

*NOTE: F-Blades (Urethane) can be used on mechanically fastened belts and vulcanized belts.

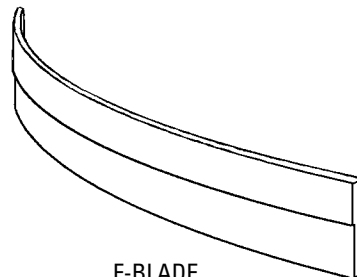

F-BLADE

Section 10 - Other Flexco Conveyor Products

Flexco provides many conveyor products that help your conveyors to run more efficiently and safely. These components solve typical conveyor problems and improve productivity. Here is a quick overview on just a few of them:

MMP Precleaner



- Extra cleaning power right on the head pulley
- A 10" (250mm) TuffShear™ blade provides increased blade tension on the belt to peel off abrasive materials
- The unique Visual Tension Check™ ensures optimal blade tensioning and quick, accurate retensioning
- Easy to install and simple to service

DRX Impact Beds



- Exclusive Velocity Reduction Technology™ to better protect the belt
- Slide-Out Service™ gives direct access to all impact bars for change-out
- Impact bar supports for longer bar life
- 4 models to custom fit to the application

MHS Secondary Cleaner with Service Advantage Cartridge



- An easy slide-out cartridge for service
- Cartridge design to speed up blade-change maintenance
- Patented PowerFlex™ Cushions for superior cleaning performance
- Compatible with Flexco mechanical splices

PT Max™ Belt Trainer



- Patented “pivot & tilt” design for superior training action
- Dual sensor rollers on each side to minimize belt damage
- Pivot point guaranteed not to seize or freeze up
- Available for topside and return side belts

Flexco Specialty Belt Cleaners



- “Limited space” cleaners for tight conveyor applications
- High Temp cleaners for severe, high heat applications
- A rubber fingered cleaner for chevron and raised rib belts
- Multiple cleaner styles in stainless steel for corrosive applications

Belt Plows



- A belt cleaner for the tail pulley
- Exclusive blade design quickly spirals debris off the belt
- Economical and easy to service
- Available in vee or diagonal models

The Flexco Vision

To become the leader in maximising
belt conveyor productivity for our customers worldwide
through superior service and innovation.



1995 Oak Industrial Dr. NE • Grand Rapids, MI 49505 U.S.A.
Telephone: (616)-459-3196 • Fax: (616)-459-4976 • E-mail: info@flexco.com • Web: www.flexco.com

Australia: 61-2-9680-3322 • China: 86-21-33528388 • England: 44-1274-600-942
Germany: 49-7428-9406-0 • Mexico: 52-55-5674-5326 • South Africa: 27-11-608-4180